

CANVAS



Müller Ullmann COLLECTION

EZO
B O R D



MEET CANVAS

LONELY TREE by Vlad Muller - 43"W x 90"H x 2"D Panel

Personalize Your Space with Acoustic Artistry

Canvas is a unique fusion of art and acoustic innovation that transcends traditional wall decor. Easy to mount, Canvas proficiently reduces noise and reverberation while providing both a visually striking and sonically soothing experience.

Crafted with EzoBord's sustainable PET material and unique EzoPrint process using local in-house production resources, Canvas displays the captivating works of independent artists like Vlad Müller and Oli Ullman. Vlad's aerial photography captures nature's beauty from a fresh perspective, while Oli's vibrant images invite us to connect with the energetic essence of landscapes.

With a versatile range of configurations and orientations, you can now customize the aesthetics of your wall space and punctuate any environment where people live and work.

Experience Canvas by EzoBord today!



VladMüller

Advancements in aerial photography 15 years ago inspired Vlad to trade his paint brush for camera drones, which quickly evolved into an obsession with celebration of ordinary, everyday surroundings and nature while travelling in Canada and around the world. Even a small change in the height of the camera literally offers a new perspective. It is this moment of surprise, the pause when we examine the unknown, which is an opportunity to expand our horizons and challenge how we perceive and understand the world around us.

Celebrating the ordinary is an invitation to respect, revere with gratitude, and admire the beauty that surrounds us each day. Vlad's work has received awards at international photography competitions and has been exhibited in Canada and Europe.



Oli Ullmann

Oli began practicing meditation in the 1990s, which helped her delve deeper into the world of energies. She started perceiving a broader spectrum of colors, hearing vibrational tones of the environment, and gradually gained access to communication with the surrounding world. She believes that nature is like a living library, a pure energetic template of creation. Nature became her main source of inspiration. Oli's photographs represent an invitation to meet the flowers, meadows, forests, mountains, and deserts.

Each one is so different in its beauty and energetic expression, yet they all share something in common—selfless love, majesty, and innocence—reflections of our Earth, which is undergoing rapid transformation. Oli exhibited her work in Canada and Europe.



ANIMAL FOOTPATHS 1
by Vlad Muller
EZP-MUL-002

When fishermen temporarily drain ponds in Southern Bohemia in the Fall, waterbirds and animals create muddy paths in search for remaining small fish.

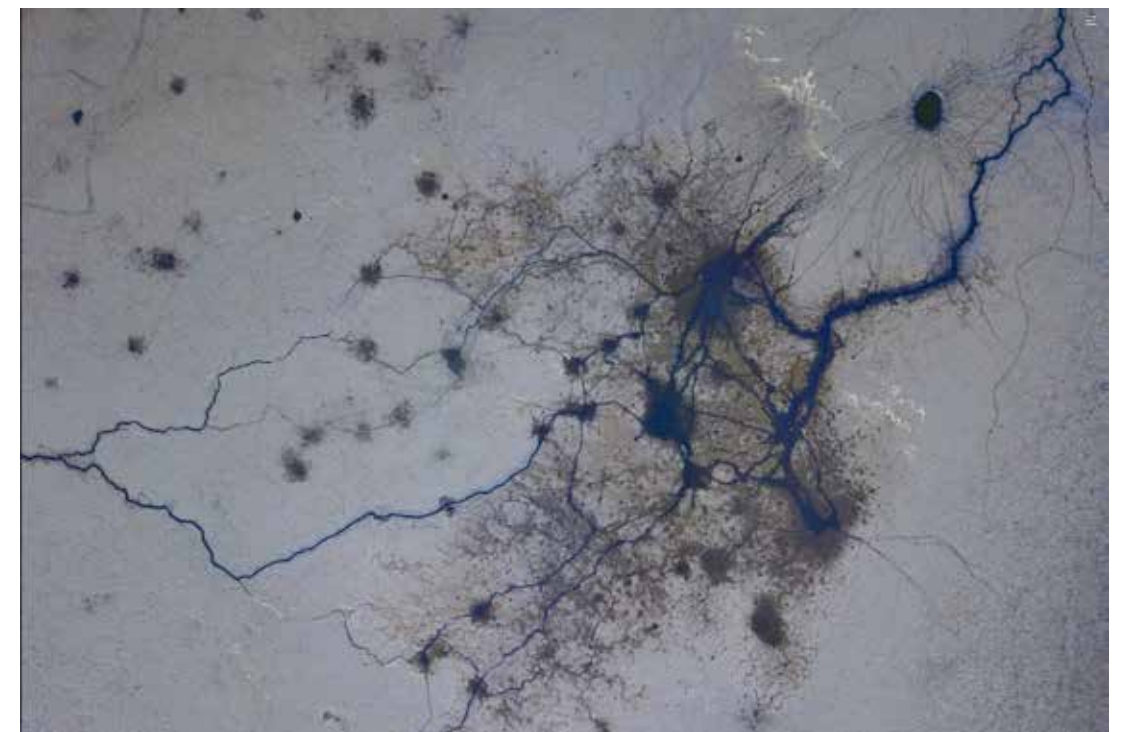

ANIMAL FOOTPATHS 2
by Vlad Muller
EZP-MUL-012

When fishermen temporarily drain ponds in Southern Bohemia in the Fall, waterbirds and animals create muddy paths in search for remaining small fish.



ICELANDIC MAGIC 1
by Oli Ullmann
EZP-MUL-004

Fragments of ice float motionlessly in a glacier lagoon. The fog slowly rises and admires its own reflection in a pool of silt water while the the moss-covered volcanic mountain range looks on.



ICELANDIC MAGIC 2
by Oli Ullmann
EZP-MUL-005

Reflection of ice, coarse snow, volcanic rock and grey sky in still waters of glacier lagoon. All is still. Only the ice has not forgotten when the sky was blue.



ICELANDIC MAGIC 3
by Oli Ullmann
EZP-MUL-006

Ice, coarse snow and volcanic rock debris playfully cocreate endless textures and intricate patterns. Sediment-rich silty water reflects and pauses in awe.



RIVER ESTUARY 1
by Vlad Muller
EZP-MUL-007

Aerial photo of an Icelandic river estuary, where vibrant green marshlands meet sediment-rich waters. The river's winding path creates intricate patterns, merging with the estuary amidst a landscape of glacial silt and volcanic ash.

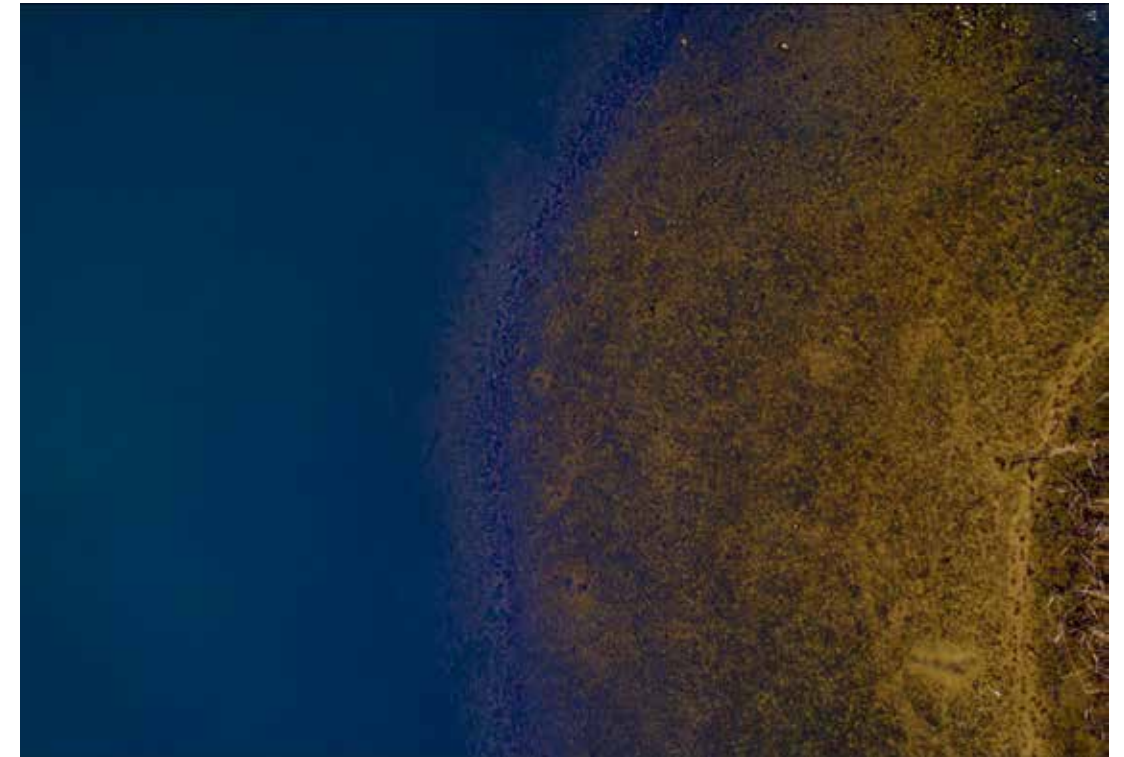

SEA BOTTOM
by Vlad Muller
EZP-MUL-011

Receding water exposes vegetation and occasional fallen leaf. Refelected blue sky contributes to the calming and contemplative mood of the scene.



RIVER ESTUARY 2
by Vlad Muller
EZP-MUL-010

Aerial photo of an Icelandic river estuary, where vibrant green marshlands meet sediment-rich waters. The river's winding path creates intricate patterns, merging with the estuary amidst a landscape of glacial silt and volcanic ash.

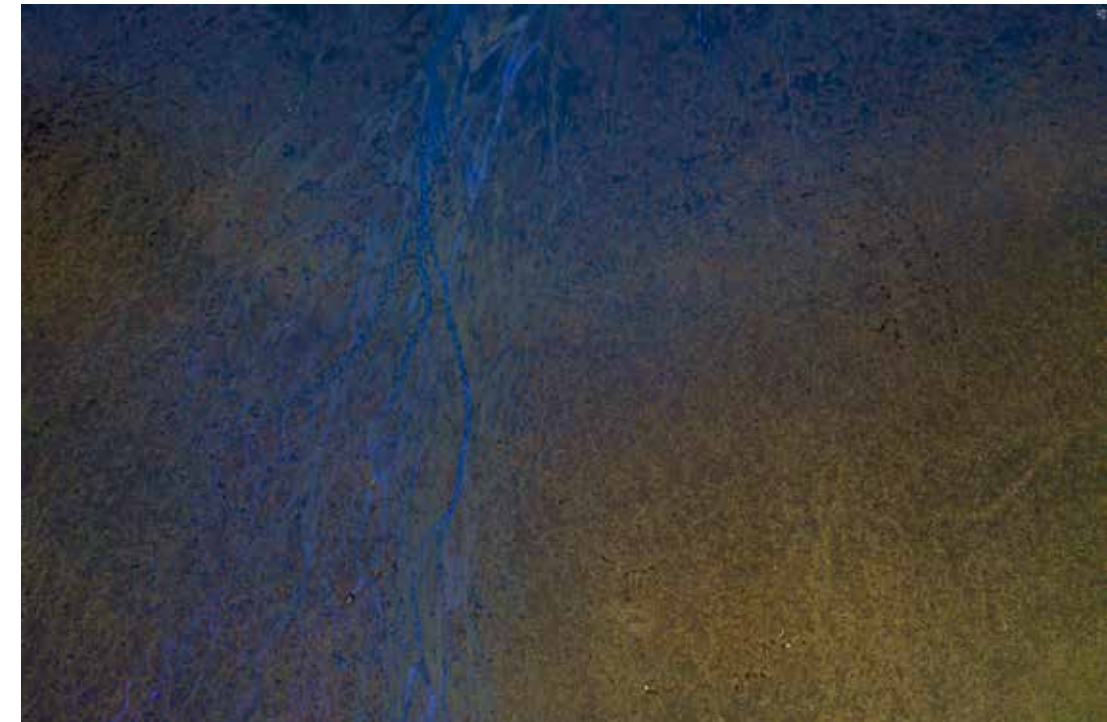

BIRTHPLACE OF RIVERS
by Vlad Muller
EZP-MUL-014

Aerial image captures tiny streams of water as they ggle with joy while embarking on a long journey, unaware yet that they will become oceans.

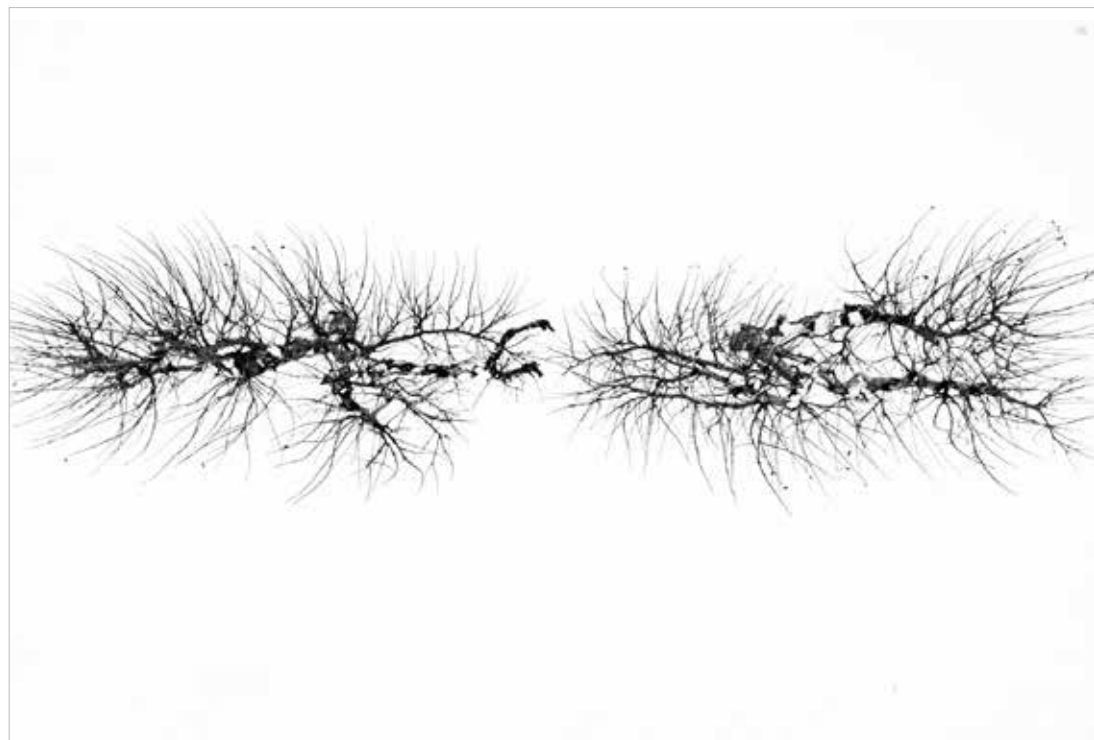

ABOVE APPLE ORCHARD

by Vlad Muller
EZP-MUL-001

Aerial view of apple trees with main branches narrowly trained to maximize access to sun light and ease the harvest in the Fall.

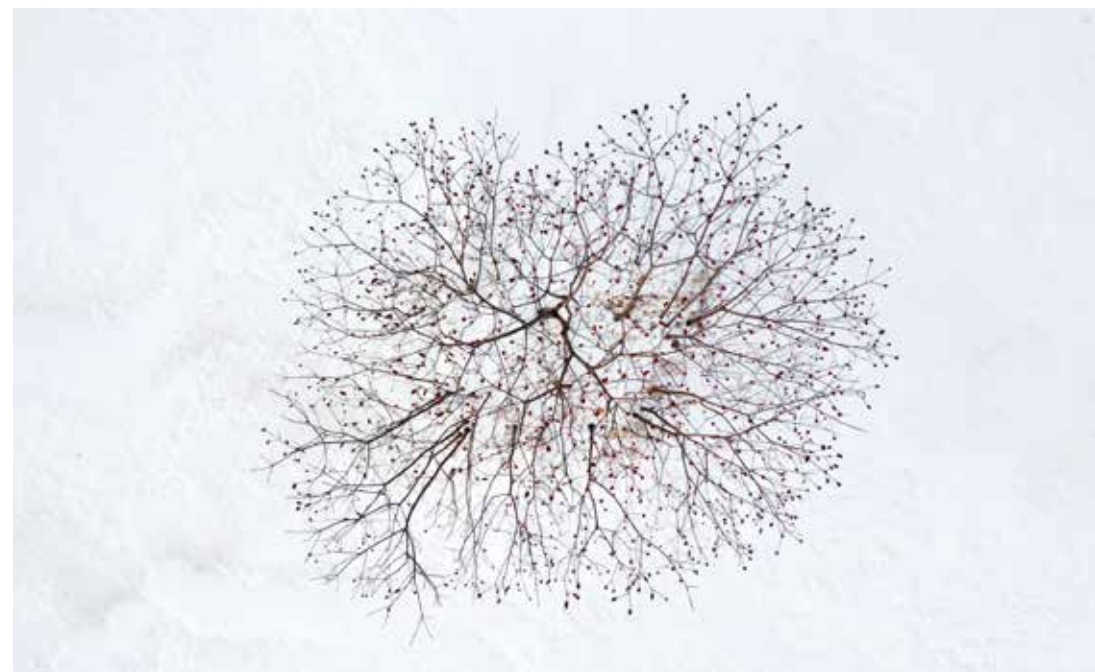

FRUITS OF WINTER

by Vlad Muller
EZP-MUL-003

Aerial view of a bush in winter, with leafless, lace-like branches eagerly extended outward, as if offering its red fruits far and wide.



LONELY TREE

by Vlad Muller
EZP-MUL-013

Aerial view of a lonely, mature tree surrounded by dormant corn field with patterns of corn stalk remains just barely protruding through the snow on the ground. The last sliver of setting Sun reflects briefly of the bare branches, sharing warmth and soft glow before setting down.



NETWORK
by Vlad Muller
EZP-MUL-008

Aerial view of a mature tree with its bare branches spreading out like a web against the white snow background. Late afternoon Sun highlights the moss while hints of a blue-cast shadow on the snow add depth and character to the composition.



NEURAL NETWORKS
by Vlad Muller
EZP-MUL-009

Aerial view of a cluster of trees in winter, their leafless branches delicately extend outward in intricate patterns, creating a natural lace-like texture that contrasts beautifully with the pristine white snow below. Subtle warm tones from the sunlight add a soft glow, bringing some warmth to the chilly scene. The image evokes a sense of stillness, harmony and community, highlighting the beauty of nature in its dormant state.



ICELANDIC MAGIC 3 by Oli Ullmann - 3 Section Composition of 43"W x 90"H x 2"D Panels



RIVER ESTUARY 2 by Vlad Muller - 43"W x 43"H x 2"D Panel

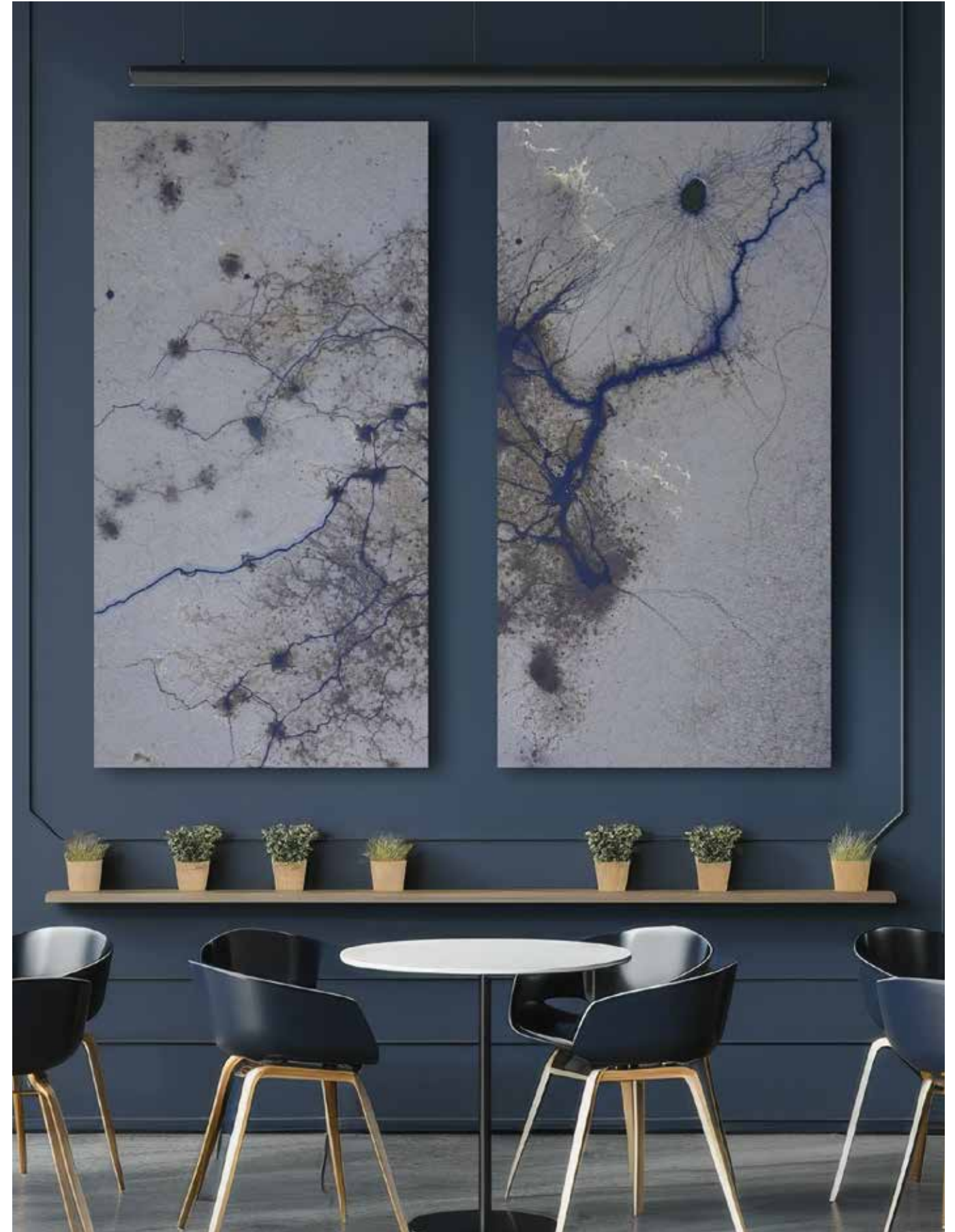

ANIMAL FOOTPATHS 2 by Vlad Muller - 2 Section Composition of 43"W x 90"H x 2"D Panels



SEA BOTTOM by Vlad Muller - 2 Section Composition of 43"W x 43"H x 2"D Panels



FRUITS OF WINTER by Vlad Muller - 43"W x 43"H x 2"D Panel



KNOW MORE
AT EZOBORD.COM

EXPLORE OTHER
ARTIST PATTERNS

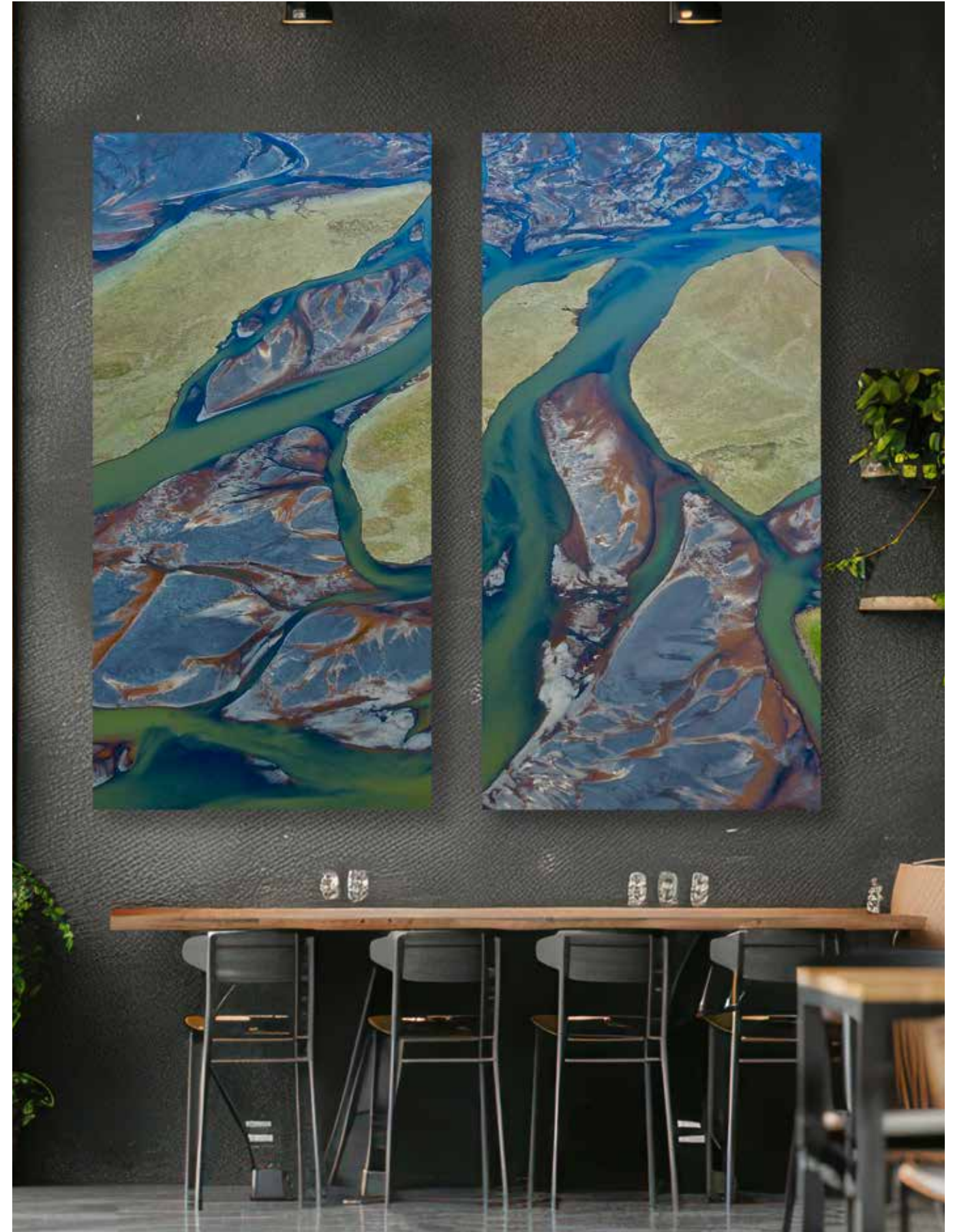
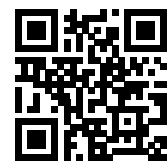

RIVER ESTUARY 1 by Vlad Muller - 2 Section Composition of 43"W x 90"H x 2"D Panels



NEURAL NETWORKS by Vlad Muller - 3 Section Composition of 43"W x 90"H x 2"D Panels

SIZES

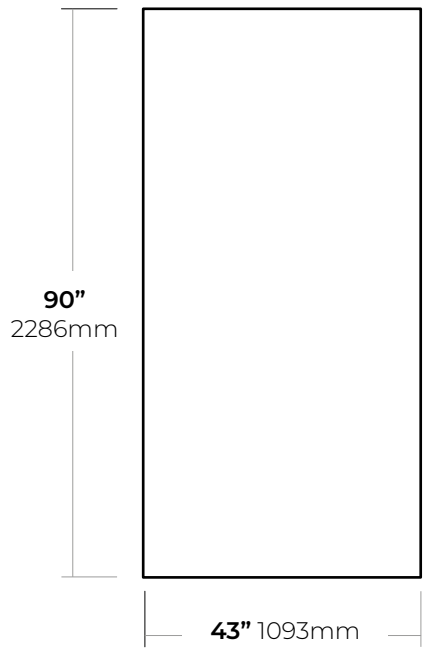

WIDTH	HEIGHT	DEPTH
90" 2286mm	43" 1093mm	2" 48mm
43" 1093mm	90" 2286mm	2" 48mm
43" 1093mm	43" 1093mm	2" 48mm



Corner detail

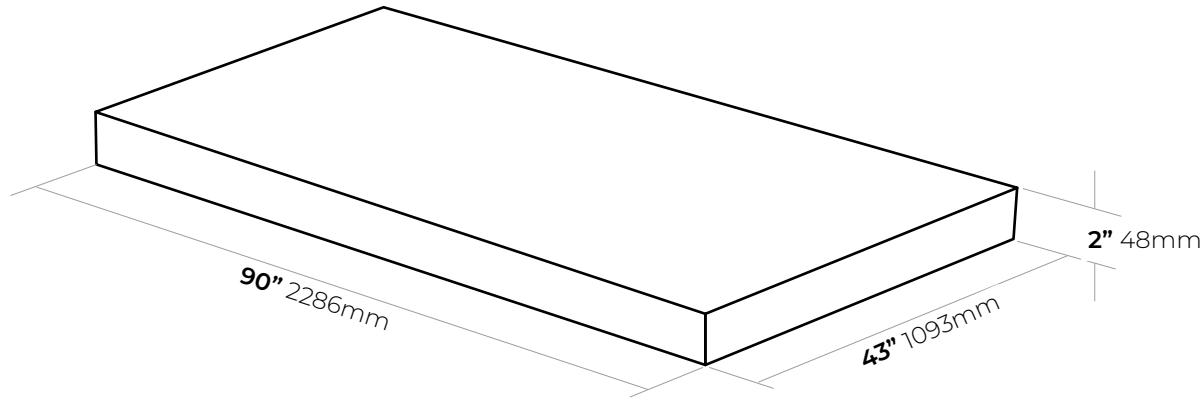
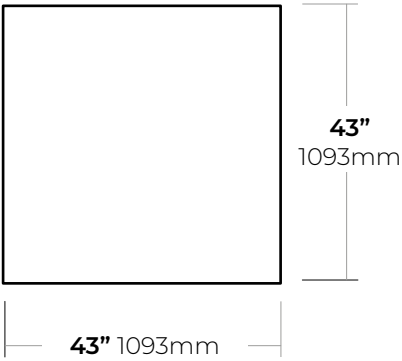
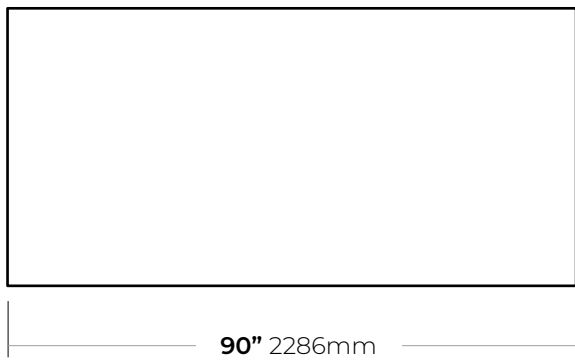

EZO Z CLIP MOUNTING BAR

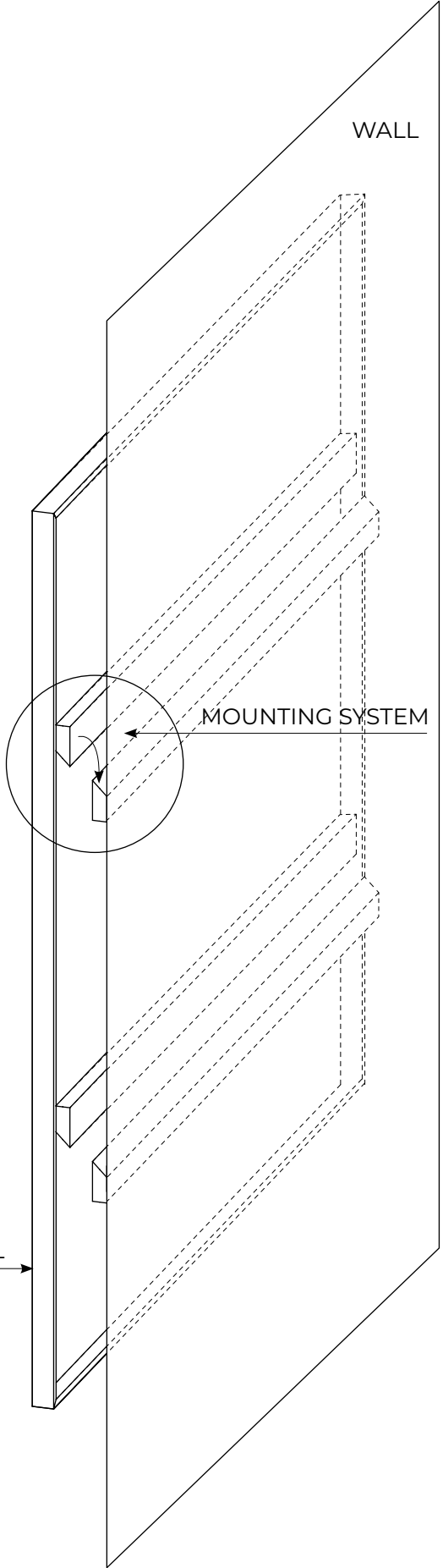
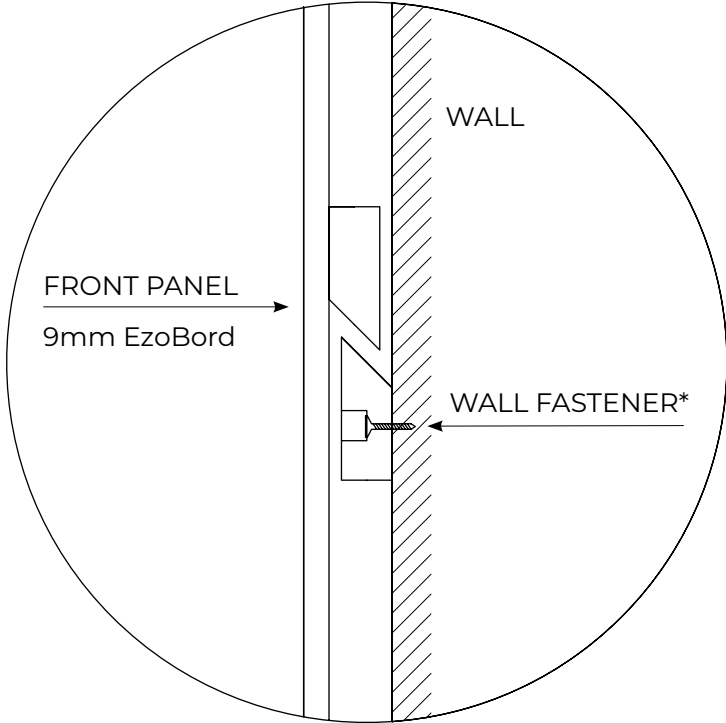

*wall fastener not included

SPECIFICATIONS

COMPOSITION

9mm EzoPrint, 100% PET (min 50% recycled content)* acoustic panel with integrated air cavity and self contained mounting kit.

CLEANING

Remove dust and dirt with gentle vacuuming (no brush) or light application of compressed air. Care should be taken not to rub or abrade the surface. Warm distilled water may be used to remove stains. If necessary, a color safe cleaning solution may be used. If using a cleaner be sure to test in an inconspicuous location first. Do not use bleach or solvent based cleaners.

FIRE TESTING

NORTH AMERICA:

- ASTM E-84 Class A*
- CAN ULC S102-10

EUROPE AND UK:

- EN13501-1: 2007

ENVIRONMENT

This product is made from 100% polyester fiber with minimum 50% recycled content and contributes to LEED MR Credit and BREEAM Health and Wellbeing Materials points due to recycled content, acoustic performance, and low VOC emitting materials. Other specifications include:

- Low VOC, CDPH v1.2 compliant
- Reach Compliant
- Declare - Red List Free
- Health Product Declaration
- Zero waste manufacturing initiative

USGBC LEED V4 CREDITS

While individual products do not 'earn' LEED credits, EzoBord can contribute to the following LEED v4 Credits. Please refer to the USGBC LEED credit guides for detailed requirements.

- EQc9 for enhancing acoustic performance
- MRc3 BPDO for sourcing of raw materials for recycled contribution
- EQc6 interior lighting for surface reflectance (lighter color options).

NOISE REDUCTION

Noise Reduction Coefficient (NRC): 0.75

Reference test report

"EzoBord 3/8" (9mm) w/D50 mount"

Refer to ASTM C423 test chart for specific absorption rates/frequency.

SOUND ABSORPTION COEFFICIENTS

ASTM C423-17

NRC	SAA	125	250	500	1000	2000	4000
0.75	0.76	0.08	0.33	0.71	1.00	1.03	0.93

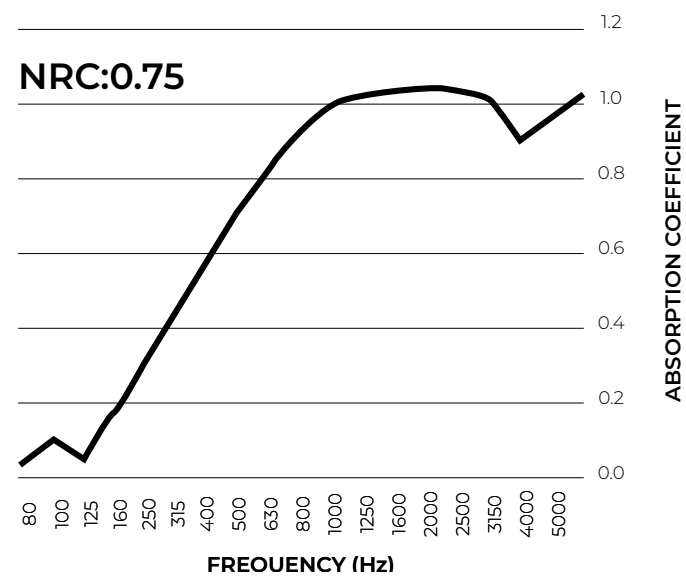

ENVIRONMENT

Our Commitment to the Environment

There are approximately 50 billion water bottles consumed around the world each year, and only about half of those get recycled. The rest end up in landfills, littered through our neighborhoods, or floating in our oceans.

Bottled water consumption has more than doubled since 2000; in 2015 there was the equivalent of more than 5 bottles of water consumed for every person in the USA every single week. This, of course, means that the amount of oil required to produce the energy used for the water bottling process continues to grow.

In 2007, the last year global statistics of oil consumption were available, between 32 million and 54 million barrels of oil were used to produce the bottled water that was consumed in the USA alone. This energy is used to make the bottles from PET pellets (1 million tons in the USA), treat water, bottle the water, label the bottles, and transport the bottled water. Most of the energy consumption occurs in the creation of the bottles themselves. To help in the lifecycle of this plastic product, we have chosen to manufacture our material so that it recycles these PET bottles. We are doing our part to reduce the waste. This acoustical and tackable material is made from PET bottles in a zero-waste process with postindustrial recycling. An environmentally friendly, sustainable, and waste reduced alternative to traditional acoustical/tackable material that looks great in any office, education, or open space installation.

EzoBord is



- low VOC
- formaldehyde free

DID YOU KNOW...

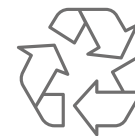

For every pound of recycled PET bottles (approximately 23) energy use is reduced by 84% and greenhouse gas emissions are reduced by 71%.

PET BOTTLES

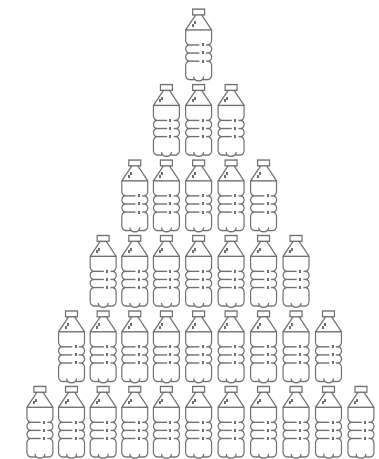

± 166 pet bottles are used to make one 3/8" 9mm thick EzoBord sheet.

± 318 pet bottles are used to make one 1/2" 12mm thick EzoBord sheet.



DESIGN
DRIVEN
ACOUSTICS

CANADA

Ayrsonics Inc - Ontario

825 Trillium Drive
Kitchener, Ontario N2R 1J9
844-441-1122
sales@ayrsonics.com

Ayrsonics Inc - Alberta

292236 Nose Creek Boulevard
Building 1B, Unit #19
Rocky View County, AB T4A 3N7
844-441-1122
sales@ayrsonics.com

EzoBord Corporate Office

6845 Rexwood Road, Unit 7
Mississauga, ON L4V 1S5
416-665-3571
info@ezobord.com

UNITED STATES

Ayrsonics Midwest LLC

820 Tollgate Road
Elgin, IL 60123
800-517-0686
sales.amw@ayrsonicsusa.com

Ayrsonics Southwest LLC

13430 N Dysart Rd. Suite 120
Surprise, AZ 85379
213-833-9700
sales.asw@ayrsonicsusa.com

Ayrsonics Southeast LLC

15 Enterprise Way
Dahlonega, GA 30533
706-539-4711
sales.ase@ayrsonicsusa.com

UNITED KINGDOM

EzoBord UK Limited

Unit 20, Westwood Business Park
Margate, Kent. CT9 4JJ
+44 1843-264027
sales@ezobord.co.uk

IRELAND

EzoBord Ireland Limited

Inniscarra, Main Street,
Rathcoole, Co. Dublin,
D24 EO29, Ireland
+353 1485-4774
sales@ezobord.ie

CENTRAL & LATIN AMERICA

EzoBord Costa Rica SRL

100 Sur 25 Oeste Recope
Bodega #16 Ochomogo, Cartago
+506 8842-4613
info-ebcr@ezobord.com

EzoBord - LATAM

Buenos Aires, Argentina
+54 9 11 5657-1793
info-latam@ezobord.com

FOLLOW US    