

ASSEMBLY INSTRUCTIONS

EZO ON EZO

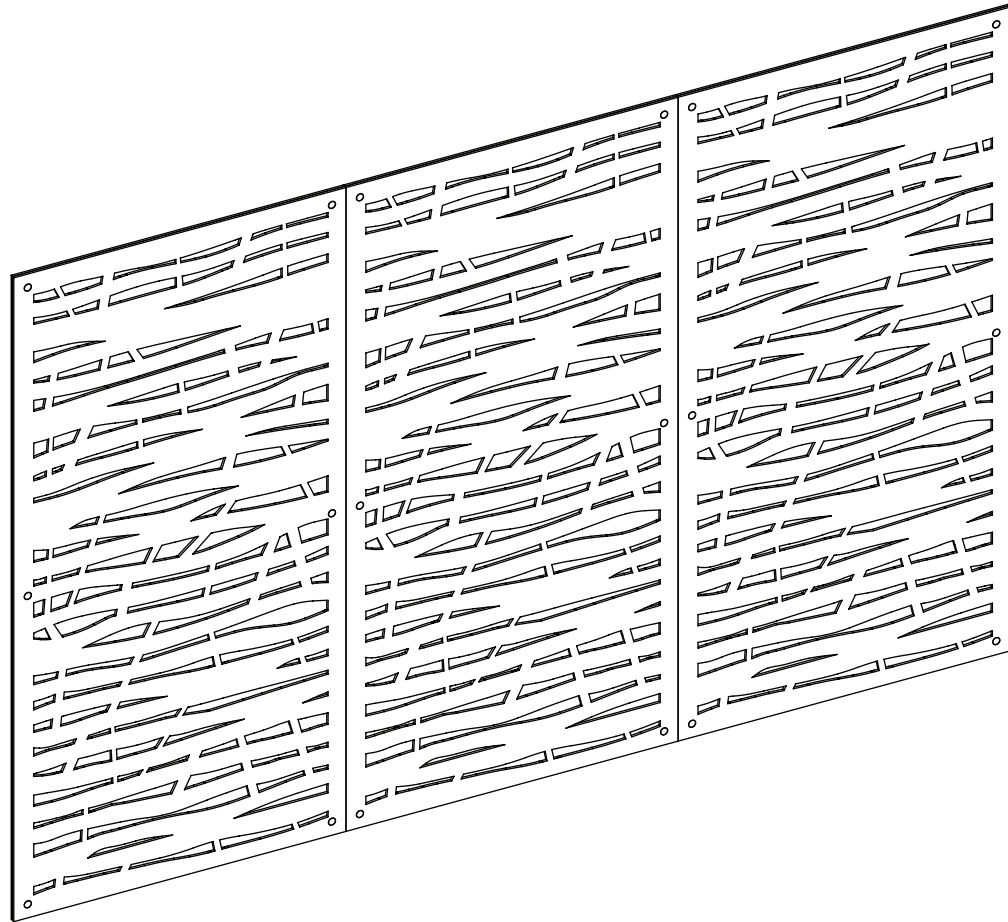

INSTALLATION HARDWARE

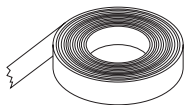

EZO TAPE

*Images reflect typical hardware options. Please refer to packing list for items & quantities specific to your order

Thank you for your order!

For questions or concerns regarding your order or installation, please contact customer service at 1-844-441-1122 or via email at sales@ayrsonics.com (Canada) or info@usa.ayrsonics.com (USA).

ASSEMBLY INSTRUCTIONS

EZO ON EZO

STANDARD MOUNTING

- 1 Remove and retain cut out plugs on top layer (6 locations).
- 2 Locate and mark Ezo on Ezo mounting location on wall.
- 3 Attach to wall with substrate appropriate fasteners(not included).
- 4 Replace Ezo plugs over fasteners.

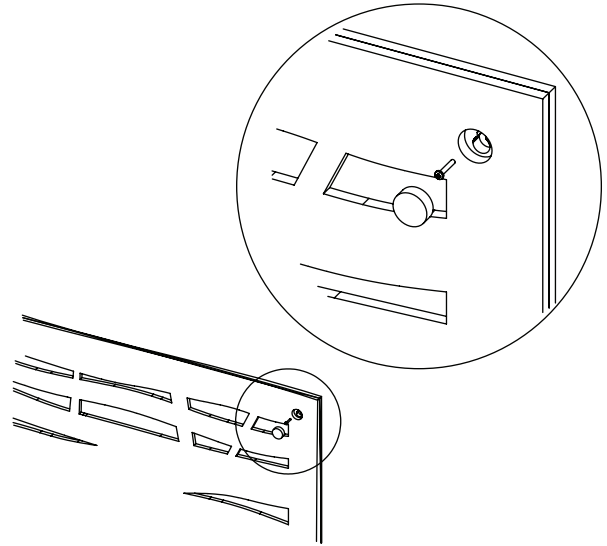

ALTERNATIVE OPTION: EZOTAPE

- 1 Apply EzoTape to outer edges of reverse side of cut panel approximately 1/8" inset from all edges.
- 2 Apply EzoTape in vertical direction every 12-16" .
- 3 Use roller to burnish tape to ensure proper adhesion to EzoBord.
- 4 Remove paper backing from tape and apply unit to wall.
- 5 Burnish ezoBord against wall with roller to ensure proper adhesion.

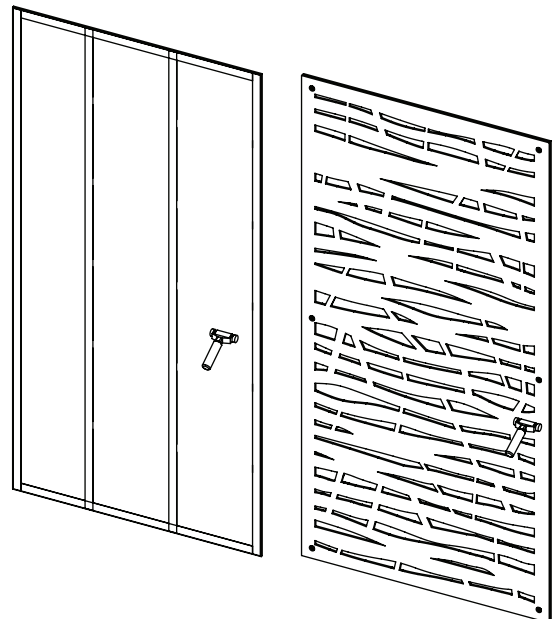

RECOMMENDED TOOLS

Laser - Level - Drill - Tape Roller - Knife

Thank you for your order!

For questions or concerns regarding your order or installation, please contact customer service at 1-844-441-1122 or via email at sales@ayrsonics.com (Canada) or info@usa.ayrsonics.com (USA).